

TECHNICAL MANUAL

**ORGANIZATIONAL, DIRECT SUPPORT, AND
GENERAL SUPPORT MAINTENANCE
REPAIR PARTS AND SPECIAL TOOLS LISTS**

FOR

**BROADBAND AMPLIFIER
(AILTECH 10512)**

HEADQUARTERS, DEPARTMENT OF THE ARMY

24 SEPTEMBER 1984

ORGANIZATIONAL, DIRECT SUPPORT, AND GENERAL SUPPORT MAINTENANCE
 REPAIR PARTS AND SPECIAL TOOLS LIST
 FOR
 BROADBAND AMPLIFIER 10512 (AILTECH)
 Washington, DC, 24 September 1984

REPORTING OF ERRORS AND RECOMMENDED IMPROVEMENTS

You can improve this manual. If you find any mistakes or if you know of a way to improve procedures, please let us know. Mail your letter, DA Form 2028 (Recommended Changes to Publications and Blank Forms), or DA 2028-2 located in the back of this manual direct to Commander, US Army Communications-Electronics Command and Fort Monmouth, ATTN: DRSEL-ME-MP, Fort Monmouth, NJ 07703. In either case a reply will be furnished direct to you.

Table of Contents

		Page	Illus Figure
Section	I. Introduction	1	
	II. Repair Parts List	5	
Group	00 Broadband Amplifier 10512 (AILTECH).....	5	1
Section	III. Special Tools List (Not Applicable)		
	IV. National Stock Number and Part Number Index	6	

i/(ii blank)

**SECTION I
INTRODUCTION**

1. Scope

This manual lists spares and repair parts; special tools; special test, measurement, and diagnostic equipment (TMDE), and other special support equipment required for performance of direct support maintenance of the 10512 (AILTECH) . It authorizes the requisitioning and issue of spares and repair parts as indicated by the source and maintenance codes.

2. General

This Repair Parts and Special Tools List is divided into the following sections:

a. Section II. Repair Parts List. A list of spares and repair parts authorized for use in the performance of maintenance. The list also includes parts which must be removed for replacement of the authorized parts. Parts lists are composed of functional groups in numeric sequence, with the parts in each group listed in figure and item number sequence.

b. Section III. Special Tools List. Not applicable.

c. Section IV. National Stock Number and Part Number Index. A list, in National item identification number (N!IN) sequence, of all National stock numbers (NSN's) appearing in the listings, followed by a list, in alphameric sequence, of all part numbers appearing in the listings. National stock numbers and part numbers are cross referenced to each illustration figure and item number appearance.

3. Explanation of Columns

a. Illustration. This column is divided as follows:

(1) Figure number. Indicates the figure number of the illustration on which item is shown.

(2) Item number. The number used to identify item called out in the illustration.

b. Source, Maintenance, and Recoverability (SMR) Codes.

(1) Source code. Source codes indicate the manner of acquiring support items for maintenance, repair, or overhaul of end items. Source codes are entered in the first and second positions of the Uniform SMR Code format as follows:

Code	Definition
------	------------

PA - Item procured and stocked for anticipated or known usage.

Code	Definition
PB	- Item procured and stocked for insurance purpose because essentiality dictates that a minimum quantity be available in the supply system.
PC	- Item procured and stocked and which otherwise would be coded PA except that it is deteriorative in nature.
PD	- Support item, excluding support equipment, procured for initial issue or outfitting and stocked only for subsequent or additional initial issues or outfittings. Not subject to automatic replenishment.
PE	- Support equipment procured and stocked for initial issue or outfitting to specified maintenance repair activities.
PF	- Support equipment which will not be stocked but which will be centrally procured on demand.
PG	- Item procured and stocked to provide for sustained support for the life of the equipment. It is applied to an item peculiar to the equipment which, because of probable discontinuance or shutdown of production facilities, would prove uneconomical to reproduce at a later time.
KD	- An item of a Depot overhaul/repair kit and not purchased separately. Depot kit defined as a kit that provides items required at the time of overhaul or repair.
KF	- An item of a maintenance kit and not purchased separately. Maintenance kit defined as a kit that provides an item that can be replaced at Organizational or Intermediate levels of maintenance.
KB	- Item included in both a Depot overhaul/repair kit and a maintenance kit.
MO	- Item to be manufactured or fabricated at Organizational level.
MF	- Item to be manufactured or fabricated at the Direct support maintenance level.
MH	- Item to be manufactured or fabricated at the General support maintenance level.
MD	- Item to be manufactured or fabricated at the Depot maintenance level.
AO	- Item to be assembled at Organizational level.

Code	Definition
AF	- Item to be assembled at direct support maintenance level.
AH	- Item to be assembled at general support maintenance level.
AD	- Item to be assembled at depot maintenance level.
XA	- Item is not procured or stocked because the requirements for the item will result in the replacement of the next higher assembly.
YB	- Item is not procured or stocked. If not available through salvage, requisition.
XC	- Installation drawing, diagram, instruction sheet, field service drawing, that is identified by manufacturer's part number.
XD	- A support item that is not stocked. When required, item will be procured through normal supply channels.

NOTE

Cannibalization or salvage may be used as a source of supply for any items coded above except those coded XA and aircraft support items as restricted by AR 750-1.

(2) Maintenance code. Maintenance codes are assigned to indicate the levels of maintenance authorized to use and repair support items. The maintenance codes are entered in the third and fourth positions of the uniform SMR code format as follows:

(a) The maintenance code entered in the third position will indicate the lowest maintenance level authorized to remove, replace, and use the support item. The maintenance code entered in the third position will indicate one of the following levels of maintenance:

<u>Code</u>	<u>Application/Explanation</u>
C	- Crew or operator maintenance performed within organizational maintenance.
0	- Support item is removed, replaced, used at the organizational level.
F	- Support item is removed, replaced, used at the direct support level.
H	- Support item is removed, replaced, used at the general support level.
D	- Support item is removed, replaced, used at depot, mobile depot, or specialized repair activity only.

(b) The maintenance code entered in the fourth position indicates whether the item is to be repaired and identifies the lowest level with the capability to perform complete repair (i.e., all authorized maintenance functions). This position will contain one of the following maintenance codes:

- | Code | Application/explanation |
|------|--|
| 0 | - The lowest maintenance level capable of complete repair of the support item is the organizational level. |
| F | - The lowest maintenance level capable of complete repair of the support item is the direct support level. |
| H | - The lowest maintenance level capable of complete repair of the support item is the general support level. |
| D | - The lowest maintenance level capable of complete repair of the support item is the depot level. |
| L | - Repair restricted to specialized repair activity. |
| Z | - Nonreparable. No repair authorized. |
| B | - No repair authorized. The item may be reconditioned by adjusting, lubricating, etc., at the user level. No parts or special tools are procured for the maintenance of this item. |

(1) Recoverability code. Recoverability codes are assigned to support items to indicate the disposition action on unserviceable items. The recoverability code is entered in the fifth position of the uniform SMR code format as follows:

- | <u>Recoverability Codes</u> | <u>Definition</u> |
|-----------------------------|--|
| Z | - Nonreparable item. When unserviceable, condemn and dispose at the level indicated in position 3. |
| O | - Repairable item. When uneconomically repairable, condemn and dispose of at organizational level. |
| F | - Repairable item. When uneconomically repairable, condemn and dispose of at the direct support level. |
| H | - Repairable item. When uneconomically repairable, condemn and dispose of at the general support level. |
| D | - Repairable item. When beyond lower level repair capability, return to depot. Condemnation and disposal not authorized below depot level. |

Recoverability
Codes

Definition

- L - Repairable item. Repair, condemnation, and disposal not authorized below depot/specialized repair activity level.
- A - Item requires special handling or condemnation procedures because of specific reasons (i.e., precious metal content, high dollar value, critical material or hazardous material). Refer to appropriate manuals/directives for specific instructions.
- c. National Stock Number. Indicates the National stock number assigned to the item and will be used for requisitioning purposes.
- d. Part Number. Indicates the primary number used by the manufacturer (individual, company, firm corporation, or government activity), which controls the design and characteristics of the item by means of its engineering drawings, specifications, standards, and inspection requirements to identify an item or range of items.

NOTE

When stock numbered item is requisitioned, the repair part received may have different part number than the part being replaced.

e. Federal Supply Code for Manufacturer (FSCM). The FSCM is a 5-digit numeric code listed in SB 708-41/42 which is used to identify the manufacturer, distributor, or government agency, etc.

f. Description. Indicates the Federal item name and, if required, a minimum description to identify the item.

g. Unit of Measure (U/M). Indicates the standard of the basic quantity of the listed item as used in performing the actual maintenance function. This measure is expressed by a two-character alphabetical abbreviation (e.g., ea, in, pr, etc.). When the unit of measure differs from the unit of issue, the lowest unit of issue that will satisfy the required units of measure will be requisitioned.

h. Quantity Incorporated in Unit. indicates the quantity of the item used in the breakout shown on the illustration figure, which is prepared for a functional group, subfunctional group, or an assembly.

4. Special Information

a. The following publication pertains to the 10512 and its components:

TM 11-6625-3070-13-1,13-2, Broadband Amplifier 10512 (AILTECH) (To be published).

b. National stock numbers (NSN's) that are missing from P source coded items have been applied for and will be added to this TM by future change/ revision when they are entered in the Army Master Data File (AMOF). Until the NSN's are established and published, submit exception requisitions to: Commander, (IS Army Communications-Electronics Command and Fort Monmouth, ATTN: DRSEL-MM, Fort Monmouth NJ 07703 for the part required to support your equipment.

5. How to Locate Repair Parts

a. When National stock number or part number is known.

(1) First. Using the table of contents, determine the functional group within which the item belongs. This is necessary since illustrations are prepared for functional groups and listings are divided into same groups.

(2) Second. Find the illustration covering the functional group to which the item belongs.

(3) Third. Identify the item on the illustration and note the illustration figure and item number of the item.

(4) Fourth. Using the repair parts listing, find the figure and item number noted on the illustration.

b. When National stock number or part number is known.

(1) First. Using the index of National stock numbers and part numbers, find the pertinent National stock number or part number. This index is in NIIN sequence followed by a list of part numbers in alphabetic sequence, cross-referenced to the illustration figure number and item number.

(2) Second. After finding the figure and item number, locate the figure and item number in the repair parts list.

6. Abbreviations

Not applicable.

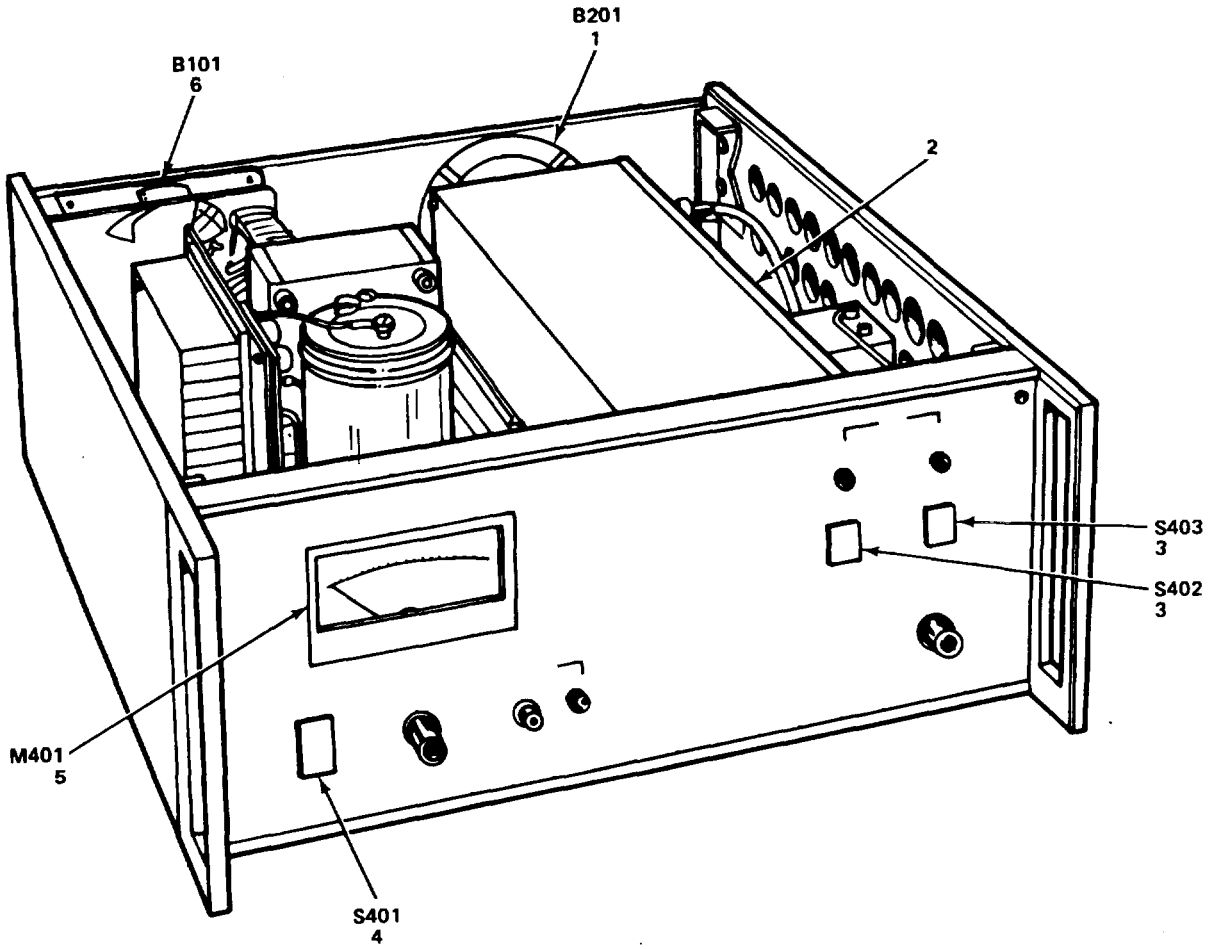

EL91H-1

Figure 1. Broadband Amplifier, 10512 (Sheet 1 of 2)

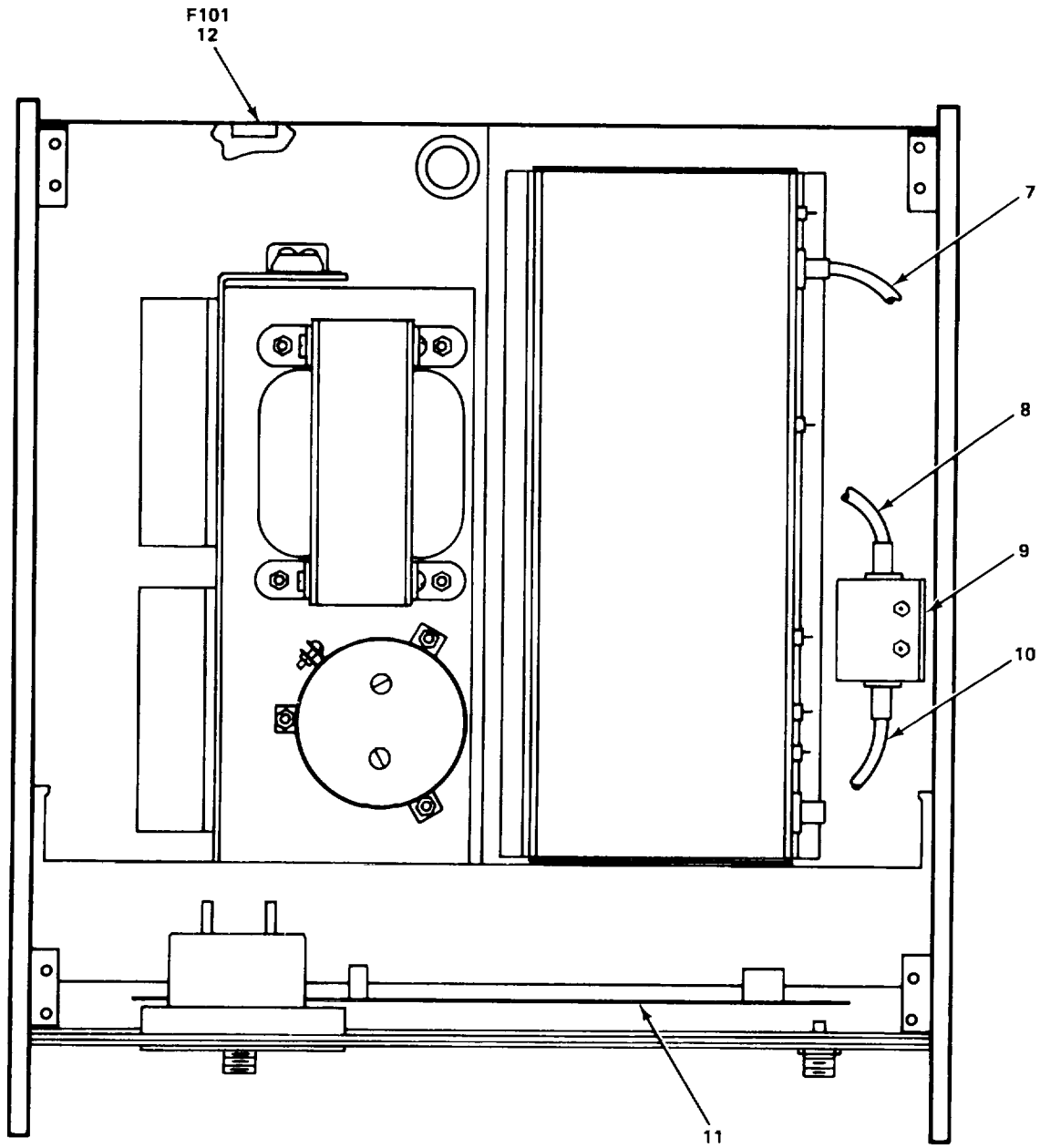

TOP VIEW
(FRONT)

EL91H-2

Figure 1. Broadband Amplifier, 10512 (Sheet 2 of 2)

SECTION II

TM 11-6625-3070-24P

(1) ILLUSTRATION		(2)	(3)	(4)	(5)	(6)	(7)	(8)
(a) FIG NO.	(b) ITEM NO.	SMR CODE	NATIONAL STOCK NUMBER	FSCM	PART NUMBER	DESCRIPTION USABLE ON CODE	U/M	QTY INC IN UNIT
						GROUP 00 BROADBAND AMPLIFIER 10512 (AILTECH)		
1	1	PAFZZ	4140-00-081-6144	23936	7600S	FAN, VENTILATING.....	EA	1
1	2	PAFDD		88869	8852-1131-2	AMPLIFIER	EA	1
1	3	PAFZZ		09353	7101J510022	SWITCH, PUSH.....	EA	2
1	4	PAFZZ		09353	7101J627022	SWITCH TOGGLE	EA	2
1	5	PAFZZ		12678	8856-5436	METER.....	EA	1
1	6	PAFZZ	4140-01-045-4414	23936	4600	FAN, TUBEAXIAL	EA	1
1	7	PAFZZ		12678	8852-1089	CABLE ASSEMBLY	EA	1
1	8	PAFZZ		12678	8852-1090	CABLE ASSEMBLY	EA	1
1	9	PAFDD		88869	8852-1136	COUPLE	EA	1
1	10	PAFZZ		12678	8852-1091	CABLE ASSEMBLY	EA	1
1	11	PAFZZ		12678	852-1267	PANEL BOARD.....	EA	1
1	12	PAFZZ	5920-00-142-7375	13499	264-0112-000	FUSE, CARTRIDGE.....	EA	1
						5		

SECTION IV

TM 11-6625-3070-24P

NATIONAL STOCK NUMBER AND PART NUMBER INDEX

STOCK NUMBER	FIG.	ITEM	STOCK NUMBER	FIG.	ITEM
4140-00-081-6144	1	1	4140-01-045-4414	1	6
5920-00-142-7375	1	12			

FSCM	PART NUMBER	FIGURE NO.	ITEM NO.	FSCM	PART NUMBER	FIGURE NO.	ITEM NO.
12674	B852-1084	1	7	13499	264-0112-000	1	12
12678	B852-1090	1	8	23936	4600	1	6
12678	B852-1091	1	10	09353	7101J51CQ22	1	3
8eR69	8852-1131-2	1	2	09353	7101J62ZQ22	1	4
86869	8852-1136	1	9	23936	76005	1	1
12673	8856-5436	1	5	12878	852-1267	1	11

By Order of the Secretary of the Army:

JOHN A. WICKHAM JR.
General, United States Army
Chief of Staff

Official:

ROBERT M. JOYCE
Major General, United States Army
The Adjutant General

Distribution:

To be distributed in accordance with special list

RECOMMENDED CHANGES TO EQUIPMENT TECHNICAL PUBLICATIONS



THEN... JOT DOWN THE DOPE ABOUT IT ON THIS FORM, CAREFULLY TEAR IT OUT, FOLD IT AND DROP IT IN THE MAIL!

SOMETHING WRONG WITH THIS PUBLICATION?

FROM: (PRINT YOUR UNIT'S COMPLETE ADDRESS)

DATE SENT

PUBLICATION NUMBER

TM 11-5825-270-10

PUBLICATION DATE

23 Jul 81

PUBLICATION TITLE

Radio Frequency R-2176/FRN

BE EXACT... PIN-POINT WHERE IT IS

PAGE NO.

PARA-GRAPH

FIGURE NO.

TABLE NO.

IN THIS SPACE TELL WHAT IS WRONG AND WHAT SHOULD BE DONE ABOUT IT:

TEAR ALONG PERFORATED LINE

PRINTED NAME, GRADE OR TITLE, AND TELEPHONE NUMBER

SIGN HERE:

DA FORM 2028-2 JUL 79

PREVIOUS EDITIONS ARE OBSOLETE.

P.S.—IF YOUR OUTFIT WANTS TO KNOW ABOUT YOUR RECOMMENDATION MAKE A CARBON COPY OF THIS AND GIVE IT TO YOUR HEADQUARTERS.

